

POLARIS

MANUAL

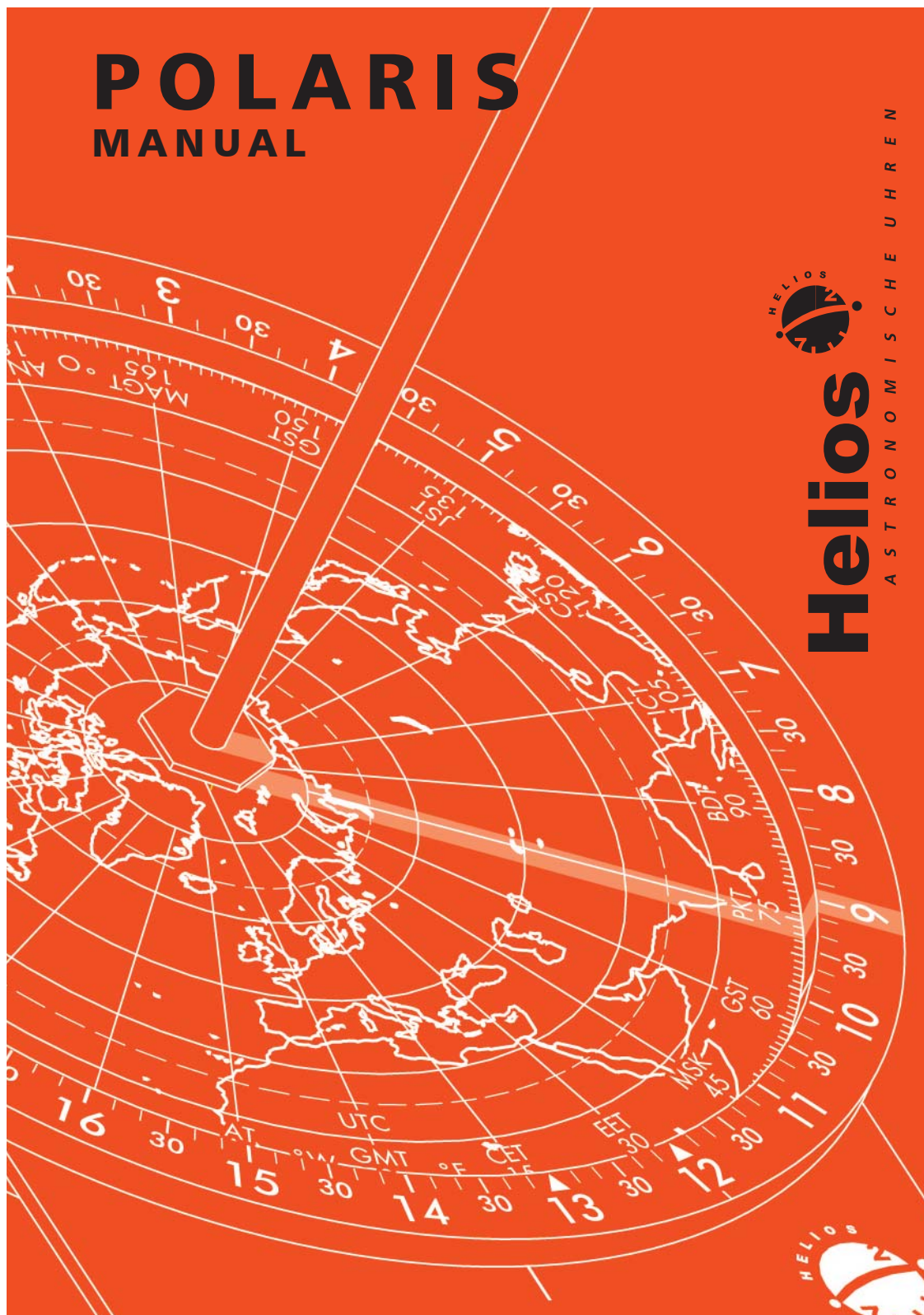

Helios

ASTRONOMISCHE UHREN



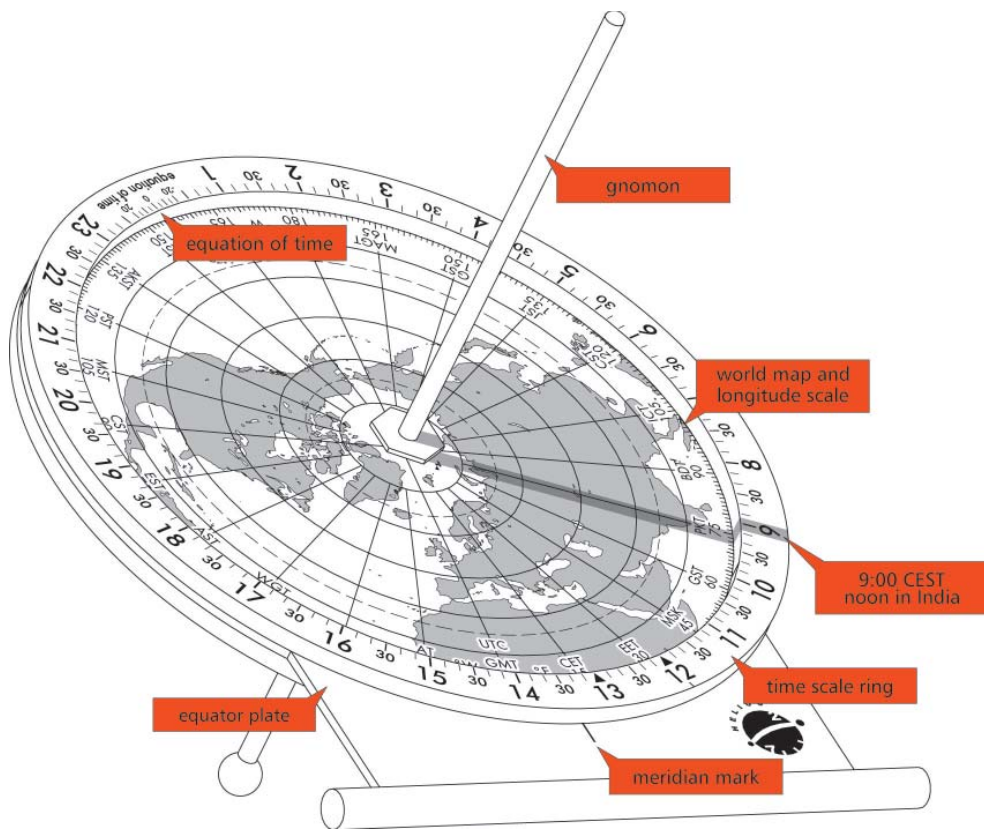

Fig. 1: POLARIS sundial

The POLARIS sundial

“But it does move” the Italian physicist, mathematician, philosopher and astronomer Galileo Galilei is supposed to have murmured, when he was forced to renounce the Copernican system at an advanced age, standing before the Spanish Inquisition.

In the meantime, Galilei has been rehabilitated by the church and today we know without a doubt that the Earth revolves around the Sun and around its own axis, which points toward the Polaris.

The POLARIS sundial has a gnomon, which stands parallel to the Earth’s axis. As the Earth revolves, the Sun seems to move around the gnomon, which illustrates the position of the Sun on the world map with its shadow.

For example, in figure 1, the POLARIS shows that the Sun is positioned above western India, so that it is noon in Bombay. Simultaneously, you can read 9:00 CEST where the shadow falls on the time ring. This is exactly the time shown on your wristwatch and not self-evident, since sundials normally display solar time.

Solar time

Solar time reproduces the natural path of the Sun at our location. It is therefore often called local apparent time (LAT). When the Sun has reached its highest point of the day (culmination), it is exactly 12:00 LAT. This point in time is local apparent noon, which effectively divides the day into two equal halves.

Even with a primitive sundial you can establish this point in time, when a stick vertically stuck into the earth casts its shortest shadow. If we monitor local apparent noon over several days using our wristwatch, we can establish that it occurs at very different times. The time from noon to noon is not always 24 hours, the solar day may be longer or shorter. During the year, the sundial may be up to 16 minutes fast and 14 minutes slow.

The reasons for the Sun’s irregular course is

the Earth’s elliptic path around the Sun and the Earth’s axis, which is tilted in comparison to its cosmic path.

Local apparent time (LAT) is not a regular time measurement and is therefore not suitable for time measurement using mechanical timepieces. For this reason, an average time, local mean time (LMT) was introduced in large towns as early as the 18th century. The difference between local apparent time and local mean time is called the equation of time. Figure 2 illustrates how the equation of time changes during the course of the year.

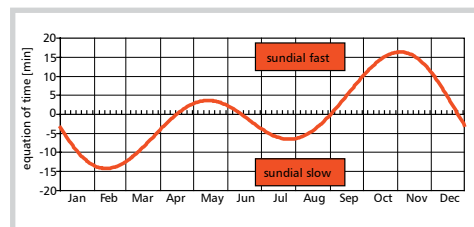

Fig. 2: Equation of time

Time zones

The invention of the railway and the telegraph during the industrial revolution of the 19th century allowed long-distance travel and worldwide communication. In particular, the need for national train timetables led to further time standardisation: the introduction of time zones via an international agreement in 1884. The time zones were positioned one hour apart, exactly the length of time required by the Sun for its migration across 15 degrees longitude of the Earth’s surface. On the POLARIS, the engraving shows the zero meridian through Greenwich in London, on which Universal Time Coordinated UTC is based, and the time zone meridians at a distance of 15° east and west.

The standard time valid for most of Europe is Central European time (CET). This is defined as the Local Mean Time (LMT) at the 15th degree of longitude east of Greenwich, on which for example the German town of Görlitz is situated. It is one hour ahead of Universal Time (UT).

Seasons

Our Earth rotates daily around its axis and migrates once around the Sun during the year. The Earth's axis is tilted vertically at an angle of $23,44^\circ$ on the plane of its own orbit. During the Earth's orbit around the Sun, the direction to the Sun is constantly changing, the Earth's axis always pointing toward the celestial pole near the Polaris. This is the reason why the Sun – as viewed from Earth – appears to migrate between the tropics during its annual orbit and the seasons evolve (figure 3).

At winter solstice on December 21st, the Sun is positioned at the southern tropics, the Tropic of Capricorn. Observed from the northern half of the Earth, it is taking its lowest daily path across the horizon. On this day the whole of the northern polar zone is in darkness. At the South Pole, in contrast, the Sun never sets on this day (polar day). From this day onwards, the Sun moves upwards and follows a higher path each day, we speak of the ascending Sun.

At the beginning of spring (First Point of Aries) on March 20th to 21st, the Sun crosses the equator (declination of 0°). Day and night are of equal length. From this day onwards, the Sun does not set in the North Pole for six months, during this time the South Pole remains in darkness. On June 20th to 21st at the summer solstice, the complete northern polar zone is lit up all day, the Sun

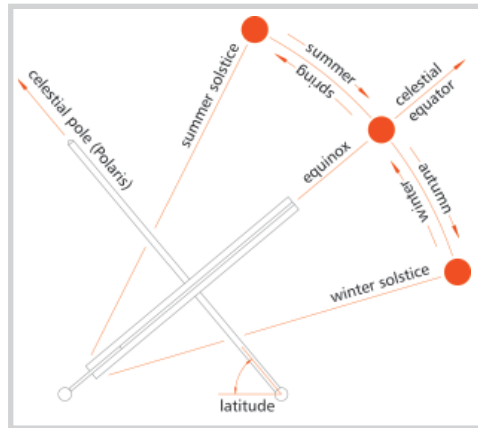

Fig. 4: Seasons

reaches the northern tropics (Tropic of Cancer), in the northern hemisphere it reaches its highest daily path.

From this date onwards, the Sun moves downwards and will cross the equator on 22nd to 23rd September in a southerly direction. It is now equinox again, the Sun is entering the zodiac sign of Libra and autumn is beginning in the northern hemisphere. On 21st to 22nd December, winter starts and the seasonal cycle recommences from the beginning.

Once the POLARIS sundial has been adjusted for its location, it is positioned like the Earth. The gnomon stands parallel to the Earth's axis and the equator plate with the world

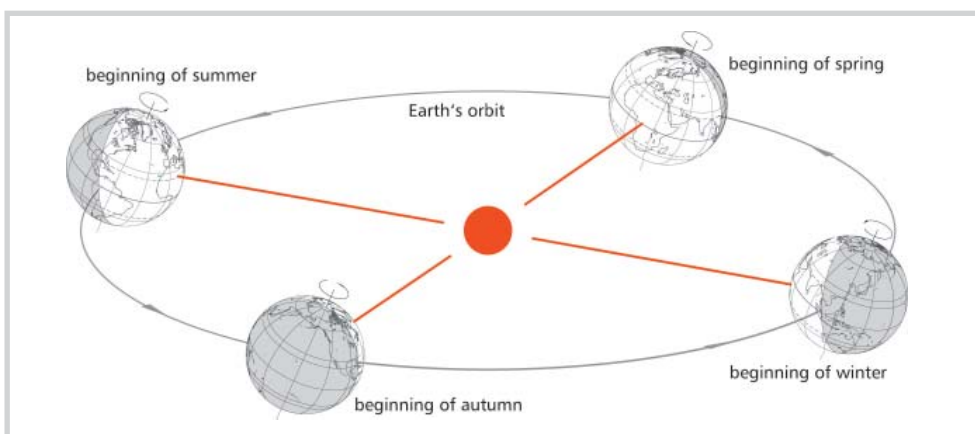

Fig. 3: Earth's migration around the Sun

map parallel to the Earth's equator level. As in real life, in spring and summer the Sun is positioned above the northern hemisphere on the world map, in winter and autumn the southern part of the world map of the POLARIS is illuminated. According to the season, the time can be read from the upper or lower part of the POLARIS. Due to its underlying design principle, the sundial does not display the time at the equinoxes (figure 4).

Setting up the sundial for its location

The POLARIS is a precision instrument, which can display the exact time and the Sun's noon position for you. The following instructions show you how to set up and adjust the sundial.

The POLARIS can be installed for any location in the median latitudes of the world. It can be adjusted with the latitude rule provided for latitudes between 35°N and 70°N on the northern hemisphere, or 35°S and 70°S on the southern hemisphere.

The installation takes place in three steps. We will take Frankfurt am Main as our location example for the sundial. The geographic coordinates for Frankfurt are: latitude 50.1°N and longitude 8.7°E.

1. Setting up your own location on the world map

The aim of this step is to set up the sundial so that the meridian line goes through your own location (figure 5). Once the sundial has been correctly installed, this imaginary line runs exactly from north to south.

The location is set by moving the longitudinal scale on the outer edge of the world map. Turn the time ring until 12:00 corresponds with the meridian mark on the equator plate. Then turn the world map until the longitude of your location appears at the 12:00 arrow. In figure 5, this is 8.7°E, the geographical longitude of Frankfurt am Main. Do the same for the lower half of the sundial with the world map of the southern

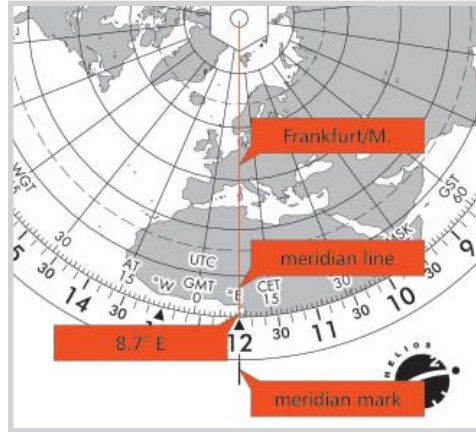

Fig. 5: Setting the longitude

hemisphere, set the longitude for your location here too. If the world map is difficult to turn, slightly loosen the central screw nut above and below with the box spanner provided.

2. Setting the latitude

The gnomon is introduced into the central hole from the southern side. Now place the sundial on a flat surface and hold the latitudinal scale at the centre of the time ring. By moving the gnomon up and down you can

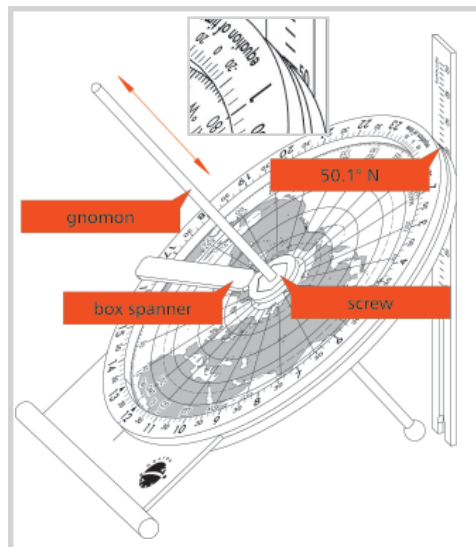

Fig. 6: Setting the latitude

now set the Polaris for the latitude (figure 6). When you have done this, tighten the screw nuts above and below with the box spanner provided. Please ensure that the setting for the longitude established during step 1 is still correct.

3. Adjusting toward the south

The time zone valid for your country can be read from the POLARIS, so that you can immediately compare this to the time on your watch. You can also set up the POLARIS by using the time on your wristwatch, so that it is automatically adjusted to the south.

The time zones are illustrated in on the world map. For Frankfurt am Main Central European time (CET) is the appropriate time zone, which is located at the longitude 15° E.

To show this, turn the time ring until the 12:00 arrow is on the time zone meridian 15° E, which is labelled "CET". If summer time (CEST) is current, use the arrow at 13:00 (figure 7).

Now you just need to set the equation of time, which is dependent on the date. This results from the fact that solar time is sometimes ahead or behind the time on our watches.

In our example we assume it is the May 15th. For this date, a value of +4 min for the equation of time can be read off the table on the last page of the manual. At 0:00 on the time ring, you will find the scale for the equation of time. Set the equation of time, orienting yourself by the time zone longi-

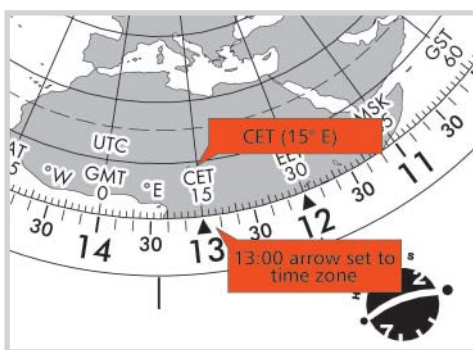

Fig. 7: Setting the time zone

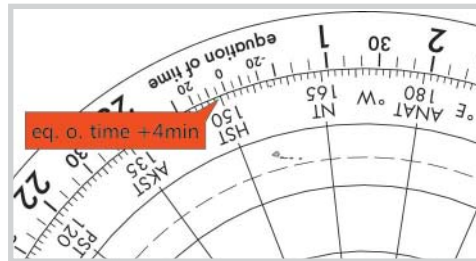

Fig. 8: Setting the equation of time

tude at which the scale is positioned after the previous setting (see figure 7 and 8).

Now everything is ready for the adjustment to the south. Set the POLARIS up at the desired location. A table or a projection in the wall could offer an appropriate setting, the surface should be flat. Now turn the sundial until the gnomon's shadow shows the same time as that on your watch (figure 9). In spring and summer from March 20th/21st until September 22nd/23rd you can read the time from the northern half (top), in autumn and winter from the southern half (bottom) (figure 4). As soon as the POLARIS' time corresponds with the time on the watch, the sundial is adjusted to the south and the gnomon points to the celestial pole near to the Polaris.

Reading from the sundial

Once you have set up the POLARIS, you can read the time and other information from the POLARIS at any time of the day.

Global timepiece

In our example, we set up the sundial for Central European Time. This is a standard time which is valid as civil time in many European countries. On the POLARIS world map, CET is drawn at the time zone meridian 15° E. Most of the other time zone meridians are identified by a representative time zone within the northern or the southern hemisphere. The meaning of the time zone abbreviations can be found on the last page of this manual.

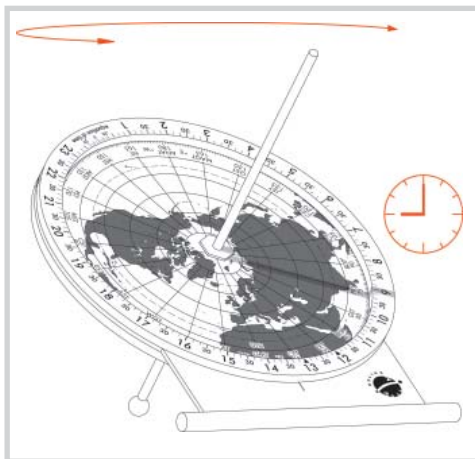

Fig. 9: Adjusting towards the south

For locations in the southern hemisphere, the gnomon is introduced from north to south, so that the southern world map is at the top. The gnomon points toward the southern celestial pole. The Sun migrates from the east via the north (instead of the south) to the west, i.e. from right to left, so that the time scale runs anti-clockwise. The POLARIS is illuminated as you would expect in the southern hemisphere: in spring and summer the top section (southern world map) and in autumn and winter the lower section (northern world map) is illuminated.

Local apparent time – solar time

Needless to say, you can also set solar time – or local apparent time (LAT) on the POLARIS for your chosen location. LAT is determined directly by the Sun. It is 12:00 LAT when the Sun reaches its highest point (culmination) at noon and passes the local meridian (noon line). The shadow then falls exactly on the longitude at which the installed position is located. Accordingly, we move the sundial until 12:00 is in congruence with the noon line. This means that we turn the time ring until the line under 12:00 points to the noon mark (figure 5). It stays here for the whole year to display LAT, a date-dependent setting similar to the equation of time does not exist for this case. The POLARIS always shows true solar time directly.

The Sun's migration around the world

Just as at your own location, noon occurs at every location on Earth. This event takes place at the longitude at which you can see the shadow line on the POLARIS world map at this moment in time. At all other locations on this longitudinal line, the Sun is currently reaching its daily culmination. In the northern hemisphere it is then exactly at the south, on the southern hemisphere in the north. In the tropical zone between the tropics, the Sun – depending on the season – appears at one of either directions and on two days in the year reaches its zenith.

In our example on May 15th at 9:00 CEST (figure 1 and 9), the Sun is 74° east of Greenwich over western India at noon. If you were to find yourself 120 km east of Bombay at this moment in time, the Sun would just be culminating in the south.

Support

If you have questions on the installation and use of your sundial, you can reach us at the following address:

HELIOS (EK)
 Begasweg 3
 65195 Wiesbaden
 Phone: +49 - (0)611 - 18 51 106
 Fax: +49 - (0)611 - 59 83 29
 Email: email@helios-sundials.com
 Homepage: www.helios-sundials.com

We are always grateful for comments and suggestions.

We wish you much enjoyment with your POLARIS on many sunny days.

Time zones

Long.	Abbr.	nothern hemisphere time zones	rel. UTC
180°W			-12 h
165°W	NT	Nome Time	-11 h
150°W	HST	Hawaiian Standard Time	-10 h
135°W	AKST	Alaska Standard Time	-9 h
120°W	PST	Pacific Standard Time	-8 h
105°W	MST	Mountain Standard Time	-7 h
90°W	CST	Central Standard Time	-6 h
75°W	EST	Eastern Standard Time	-5 h
60°W	AST	Atlantic Standard Time	-4 h
45°W	WGT	Western Greenland Time	-3 h
30°W			-2 h
15°W	AT	Azores Time	-1 h
0°	GMT	Greenwich Mean Time	0 h
15°O	CET	Central European Time	+1 h
30°O	EET	Eastern European Time	+2 h
45°O	MSK	Moscow Time	+3 h
60°O	GST	Gulf Standard Time	+4 h
75°O	PKT	Pakistan Time	+5 h
90°O	BDT	Bangladesh Time	+6 h
105°O	ICT	Indochina Time	+7 h
120°O	CST	China Standard Time	+8 h
135°O	JST	Japan Standard Time	+9 h
150°O	GST	Guam Standard Time	+10 h
165°O	MAGT	Magadan Standard Time	+11 h
180°O	ANAT	Anadyr Time	+12 h

Long.	Abbr.	southern hemisphere time zones	rel. UTC
180°W			-12 h
165°W	WST	West Samoan Time	-11 h
150°W	TAHT	Tahiti Time	-10 h
135°W	GAMT	Gambier Time	-9 h
120°W	PST	Pitcairn Standard Time	-8 h
105°W			-7 h
90°W	GALT	Galapagos Time	-6 h
75°W	PET	Peru Time	-5 h
60°W	BOT	Bolivian Time	-4 h
45°W	BRT	Brazil Time	-3 h
30°W	GST	South Georgian Time	-2 h
15°W			-1 h
0°	UTC	Universal Time Coordinated	0 h
15°O	WAT	West African Time	+1 h
30°O	CAT	Central African Time	+2 h
45°O	EAT	East African Time	+3 h
60°O	MUT	Mauritius Time	+4 h
75°O			+5 h
90°O	MAWT	Mawson Time	+6 h
105°O	WIT	West Indonesian Time	+7 h
120°O	AWST	Australian West. Stand. Time	+8 h
135°O	EIT	East Indonesia Time	+9 h
150°O	AEST	Australian East. Stand. Time	+10 h
165°O	NCT	New Caledonian Time	+11 h
180°O	NZST	New Zealand Standard Time	+12 h

Equation of time [min]

	Jan	Feb	Mar	Apr	May	Jun	Jul	Aug	Sep	Oct	Nov	Dec
1.	-3	-14	-12	-4	3	2	-4	-6	0	10	16	11
5.	-5	-14	-12	-3	3	2	-5	-6	1	12	16	9
10.	-7	-14	-10	-1	4	1	-5	-5	3	13	16	7
15.	-9	-14	-9	0	4	0	-6	-5	5	14	15	5
20.	-11	-14	-8	1	4	-1	-6	-3	6	15	14	3
25.	-12	-13	-6	2	3	-3	-7	-2	8	16	13	0
30.	-13		-5	3	3	-4	-6	-1	10	16	11	-2